

Copyright Information

All rights reserved! No part of this publication may be reproduced and stored in any form (electronic, mechanical, photocopying, recording or other forms) without obtaining written permission from Shenzhen Launch Tech Co., Ltd.(hereinafter refers to as LAUNCH). The manual is special written for the use of this machine of LAUNCH, therefore we are not responsible for any use of this information as applied to other devices.

Neither LAUNCH nor its affiliates shall be liable for damages, losses, costs, or expenses result from: user or third party's personal accident, misuse, or abuse of this unit, or unauthorized modifications, repairs, or alterations to this unit, or failure to strictly comply with LAUNCH operating and maintenance instructions.

LAUNCH shall not be liable for any damages or problems arising from the use of other accessories or parts other than original LAUNCH products or LAUNCH approved products.

Declaration: Other product names used herein are for identification purposes only and the registered trademark ownership belongs to original companies.

This equipment is intended for use by technical professionals or maintenance personnel.

Trademark Information

LAUNCH is a registered trademark of LAUNCH TECH. CO., LTD. in China and other countries. All other LAUNCH trademarks, service marks, domain names, logos, and company names referred to in this manual are property rights of LAUNCH or its affiliates. In countries where any of the LAUNCH trademarks, service marks, domain names, logos and company names has not been registered, LAUNCH claims its ownership for them. Other trademarks referred to in this manual still belong to the original registered company. You may not use any trademark, service mark, domain name, logo, or company name of LAUNCH or other companies referred to in this manual without prior permission from the owners. You may contact LAUNCH by visiting its website at <http://www.cnlaunch.com>, or writing to LAUNCH, Xinyang Building, Baqua 4th Road, Shenzhen, Guangdong Province, P. R. China, if you have any questions.

General Notice

Other product names used herein are for identification purposes only and may be trademarks of their respective

owners. LAUNCH disclaims any and all rights in those marks.

Safety Precautions



Warning

- I This manual is an integral part of the machine. Please read carefully.
- I Keep the manual for later use when maintaining the machine.
- I This machine can only be used for the designated purposes. Never use it for any other purpose.
- I The manufacturer is not held responsible for the damage incurred by improper use or use other than the intended purpose.

Precautions

- I This equipment must be operated by qualified personnel who have been gone through special training programs. Any modification or change of application range to this machine may cause direct or indirect damages to equipment without obtaining permission from manufacturer or not following the instruction of the manual.
- I KWB-4xx should be installed on the stable ground.
- I Keep 0.6M distance between the back panel and the wall for good ventilation. Enough room should be left on both sides of KWB-4xx for convenient operation.
- I Do not put KWB-4xx in a place with extreme temperature or moisture, or near the heating system, water tap, air-humidifier or furnace.
- I Do not put KWB-4xx near the window with sunlight. Protect the unit with a curtain or shield if necessary.
- I Keep the machine from dust, ammonia, alcohol, thinner or spraying binder.
- I People who are no operating the machines should be kept away when it is used.
- I Use appropriate equipment and tools, protective and safety equipment, including work clothes, blinkers, working boots and so on.
- I Pay special attention to the safety marks stuck on the machine.
- I Do not touch or approach the moving parts by hand or

body when the machine works.

- I Do not remove the safety device or keep it from working properly.
- I When the machine is moved, only exert force on the chassis. Never exert force on the principal shaft under any condition. Please carry and place it with great care.

Descriptions for Safety Signs

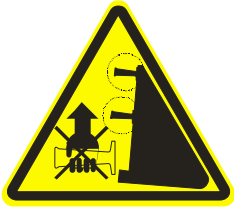

- I Do not exert force on the hanging handle to avoid falling of the machine.



- I The wheel protection must be put down before pressing START button of the machine to avoid any injury.



- I High voltage power!
Danger!



- I Do not exert force on the balance shaft when the machine is transported.

The Positions of Safety Signs

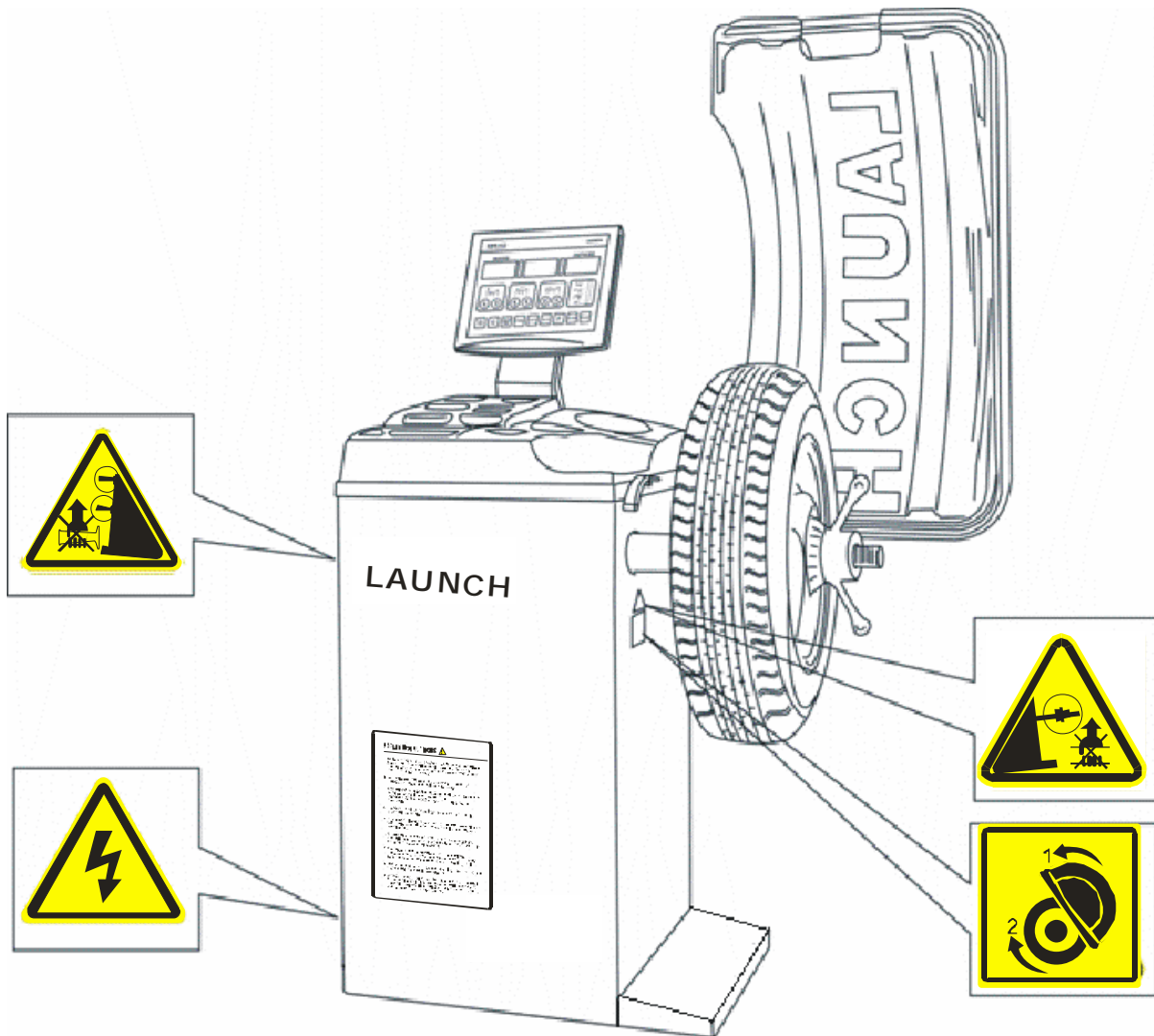

- ⌋ Please replace the safety signs if they get blurred or lost.
- ⌋ When one or more safety signs get lost, don't operate the machine.
- ⌋ The safety signs must be kept within the sight of the operator.

Table of Contents

Introduction.....	1
Usage.....	1
Features.....	1
Working Principle	1
Background Knowledge	1
Technical Parameter	1
Application Scope	1
Working Conditions	1
Equipment Structure.....	2
Main Structure.....	2
Power Supply Control Board.....	4
Control Panel	4
Operating Instruction.....	6
Preparation.....	6
Wheel Mounting	6
General operation	6
Operating Procedures for Special Balance Mode	10
ALU Wheel Drum Balance	10
OPT Coincidence Balance Operation	13
Equipment Calibration.....	15
Self-calibration Program of the Balancer	15
Automatic Measure scale Calibration Program.....	15
Self-Testing Program (Testing Position Sensors and Indicators)	16
Troubleshooting	17
Error Messages of Self-diagnosis	17
Frequent Errors and Solution.....	17
Maintenance.....	18
Storage and Scrapping.....	19
Storage	19
Scrapping.....	19
KWB-412 Circuit Diagram.....	20

Introduction

Usage

The KWB-4 series (including KWB-402/412) wheel balancer features good design, simple operation, strong functions and high measurement precision, which make it ideal equipment for measuring the dynamic balance of the wheel. It can be used for balancing small and medium size tires. It can also be a great help in car repair garage and tire shops.

Features

- I High aptitude, good stability, and high equilibrating precision.
- I The design allows you to operate from several directions; smart outline makes both eyes and minds pleased.
- I Measuring arm can automatically measure the hub diameter and the distance between the wheel and the cabinet.
- I Standard computation and calibration function eliminate the measurement deviation and ensure the test accuracy.
- I Different balance modes are available to various wheels.
- I Quick and accurate test may reduce your working intensity and improve your working efficiency.
- I Simple operation and easy grasp
- I Extra-large digital display

Working Principle

Only when CPU performs self-test and displays normal information of all units can the user start the balancing operation. CPU controls the running of principal shaft via driving interface during balancing operation. The imbalanced signal detected by the balance sensor is transmitted to CPU interface through A/D converter. CPU analyzes comprehensively both the imbalance signal and the angle signal of principal shaft, calculates the imbalance value, and then displays the result through LED unit. Man-machine dialogue can be realized through the keyboard and LED unit.

Background Knowledge

The imbalance of the wheel causes wobble of the steering wheel, low adhesion, and wheel jumping, which damages the wheel and shocks absorber and turning parts. It also influences the comfort of steering stability and increases fuel consumption, decreasing economic index of the automobile directly. Balancing operation will eliminate these disadvantages and relative loss.

Technical Parameter

Sizes

Item	KWB-402	KWB-412
Max Height	1350mm (53")	1350mm (53")
Length	1200mm (47")	1200mm (47")
Width	1000mm (39")	1000mm (39")

Noise

Working noise: <70dB (A)

Measure Index

Balance Cycle: 7s

Balance Accuracy : $\pm 1g$

Electrical Parameters

Model	Power supply	Motor Power	Max. wheel D	Max. wheel W
402	220V 50Hz	180W	10--30"	65kg
402/A	220V 50Hz	370W	10--30"	65kg
402/B	110V 60Hz	180W	10--30"	65kg
402/C	110V 60Hz	370W	10--30"	65kg
412	220V 50Hz	180W	10--30"	65kg
412/A	220V 50Hz	370W	10--30"	65kg
412/B	110V 60Hz	180W	10--30"	65kg
412/C	110V 60Hz	370W	10--30"	65kg

Weight

Item	KWB-402	KWB-412
Net Weight	108 kg	108 kg

Application Scope

Item	KWB-402	KWB-412
Rim Diameter	10—22" (254--558mm)	10--22" (254--558mm)
Rim Width	1.5--18" (38--457mm)	1.5--18" (38--457mm)
Max Wheel Weight	65kg	65kg

Working Conditions

Working Temperature: 0°C — 50°C

Relative Humidity: $\leq 85\%$

Transport/store temperature: 0°C — 55°C

Altitude: less than 1000m

Equipment Structure

Main Structure

Note: The main structure of KWB-402 and that of KWB-412 are similar, here we take KWB-412 as an example.

KWB-412 wheel balancer structure is shown as in Fig 1.

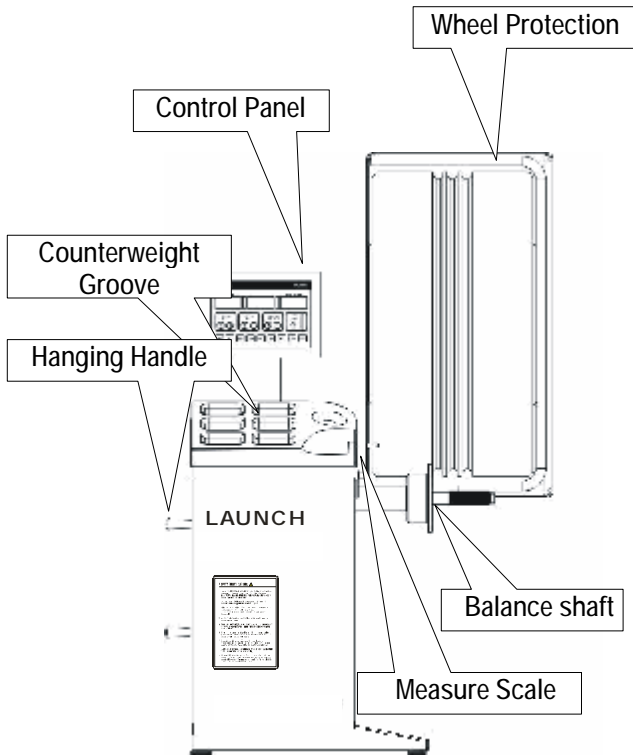

Fig 1

1. Measure scale — for automatic measurement of the installation distance of the wheel (wheel distance in short) and rim diameter, and the accurate position of the sticking balance block.

Note: The wheel distance and wheel diameter of KWB-402 need to be entered manually; and the wheel distance and wheel diameter of KWB-412 can be entered automatically.

2. Control panel — for man-machine dialogue.
3. Hanging handle-- For hanging cones and the wheel width scale
4. Counterweight groove — for putting the counterweight.
5. Balance shaft — for supporting the wheel.
6. Wheel protection: for protecting the wheel.

Accessories supplied with the machine are showed in Fig 2

No.	Description	Amount
001	Shaft positioning cone	4
002	Guide screw	1

003	Spring	1
004	Locking wing nut assembly	1
005	Width measure scale	1
006	Standard lead weight	1
007	Pliers to attach the balance weight	1
008	Hanging handle	2
009	Wheel protection	1

Standardized elements of balancer are shown in the following figure.

Standardized elements of KWB-412 wheel dynamic balancer



Fig 2

Power Supply Control Board

The position of fuse on power supply control board of the KWB-412 is shown as Fig 3.

The parameters of the two fuses F1 and F2 are:

F1: 2A, φ5×20mm, 250VAC;

F2: 6A, φ5×20mm, 250VAC。

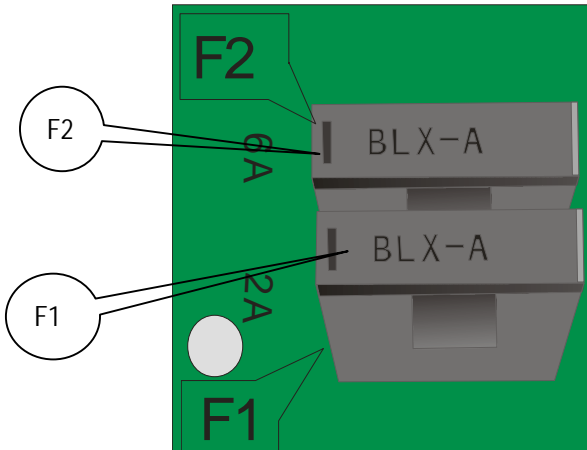

Fig 3

Control Panel

The control panel of KWB-412 is as shown in Fig. 4

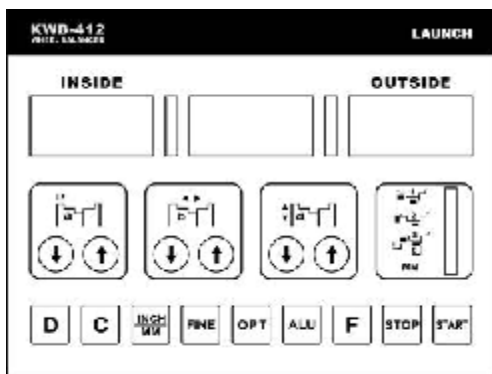
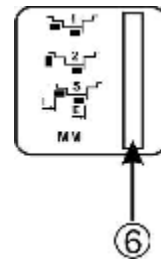
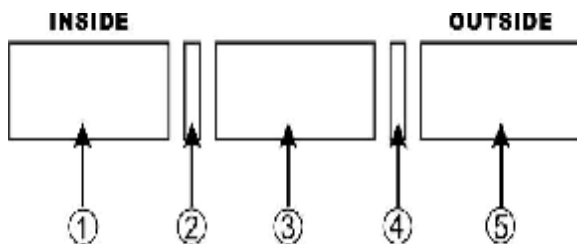

Fig 4

The meaning of display panel



1. Display for imbalance value or distance size of inner side wheel
2. Indicating for inner side balance point when all 5 indicators are lit
3. Display for static balance value or rim width
4. Indicating for outer side balance point when all 5 indicators are lit
5. Display for imbalance value or diameter size of outer side wheel
6. Indication for balance mode and "mm"

The meaning of control panel

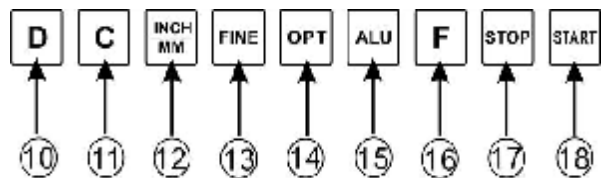
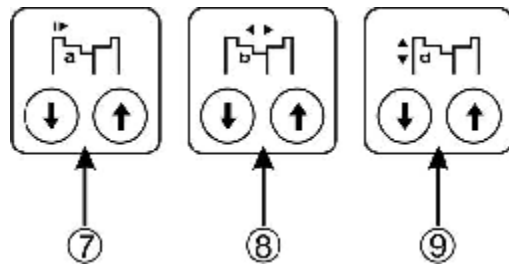

7. Key (a) used to enter the wheel distance manually
8. Key (b) used to enter the rim width manually
9. Key (d) used to enter the rim diameter manually
10. Key for self-diagnosis (LED self-check) and for self-calibration (required to be used with key C)
11. Key for dis-balance recalculation/self-calibration
12. Selection key for "inch ↔ mm"
13. High accuracy balance key
14. Dis-balance optimized key
15. Key for balance mode selection
16. Key for dynamic balance or different static balance mode selection
17. Emergency stop button
18. Start button



Caution:

In order to avoid damaging the film of control panel, please don't touch the keys with sharp material.

Composite keys for function conversion

- 1. [STOP] + [a ↑] + [a ↓] Conversion keys for the measurement unit of "gram/ounce".

First, please press [STOP] button and hold it, then press [a ↑] and [a ↓] at the same time, the information displayed on the control panel will put out; after a while, please release button [a ↑], [a ↓] and [STOP] in turn, the previous tested data will be redisplayed at once but with another kind of unit system.

Note: The different sequence for releasing the keys may result in the different data displayed, but it is not necessary for operator to perform other operations, directly pressing [Start] button is ok.

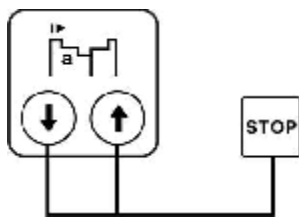

- 2. [STOP] + [C] The keys for measurement mode selection after putting down the wheel protection.

Please press [STOP] button and hold it, then press [C] button and hold it; release [C] and [STOP] button in turn, the measurement mode will be alternated between "Put down the wheel protection to start measurement" and "Put down the wheel protection to start measurement by pressing [START] button".

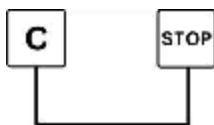

- 3. [STOP] + [FINE] The keys for entering the status of measure scale distance calibration. The self-calibration for measure scale is required to perform when starting the balancer each time, otherwise the correct measurement status cannot be entered (the detailed information about self-calibration will be described later).



- 4. [D] + [C] The keys for outside parameter calibration before measurement.

The keys are used to calibrate the CPU memories corresponding to the wheelbase, rim width and rim diameter of different wheels, so as to ensure the measurement accuracy (it is necessary to calibrate in

both Auto mode and Manual mode).

- 5. [STOP] + [OPT] Keys for diameter data adjustment of auto measure scale function. The diameter data of different vehicle wheels can be stored into CPU through this operation, and the data can keep stored even after balancer shutdown (the detailed operation will be described later).

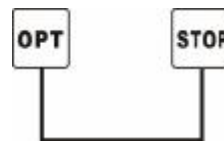

Operating Instruction



Caution:

The equipment can only be operated by qualified personnel with special training. Use appropriate tools, protective and safety equipment, wearing protective work clothes, such as blinkers, and working boots.

Preparation



Attention:

- Ø The max weight of the wheel cannot exceed 65kg.
- Ø Remove any counterweight and other foreign body from the wheel before mounting it avoiding any danger. When remove the counterweight, the demounting/mounting pliers supplied with the machine should be used (Fig. 5).
- Ø Clean the contact surfaces between the shaft and the conical casing with alcohol or gasoline before mounting the wheel to avoid any influences on installation accuracy.
- Ø Put the balancer on level ground as possible as you can.

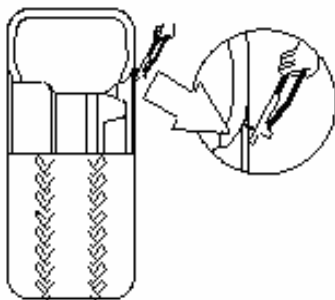

Fig 5

Wheel Mounting

Mounting Method 1

It is suitable for the wheel that can be positioned with its center hole.

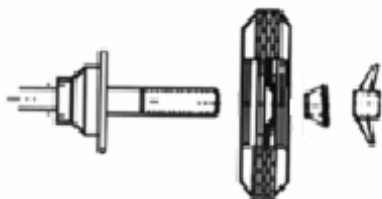
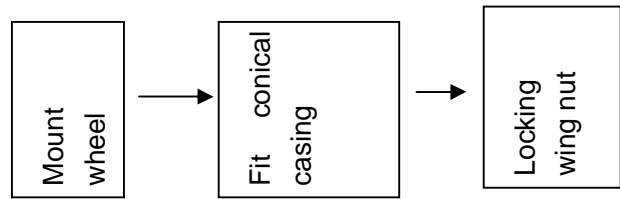

Fig 6

- I Fit the wheel onto the balance shaft close up the flange (Fig 6).
- I Select a right size conical casing, and then tighten the

wheel with a locking wing nut.



Mounting Method 2

This method is suitable for the wheel to be positioned with its central hole, especially when the central position surface cannot be correctly positioned due to deformation.

- I Fit a conical spring, then select a right size conical casing and fit it onto the balance shaft in reverse. See Fig 7.

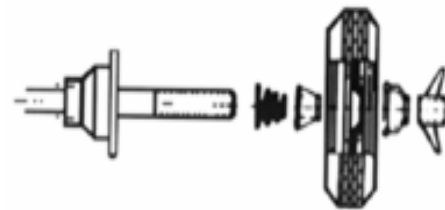
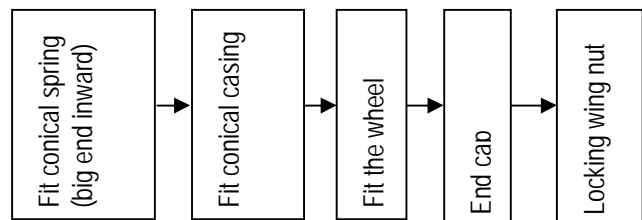

Fig 7

- I Fit a matching end cap (optional) onto the locking wing nut.
- I Fit the wheel onto the conical casing and fasten it with a end cap and a locking wing nut.



General operation

Switch on the Machine

- I Before switching on the machine, please ensure that the power supply selected meet the requirements on the name plate.
- I Turn on the power supply switch on the left side of the machine (Fig 8).

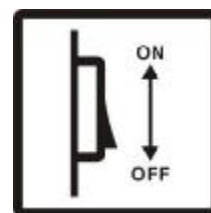

Fig 8

- I The display panel will show the version No. of main board (Fig 9).



Fig 9

- I And then the display panel will show the parameter (default value) of the object to be balanced (Fig 10).

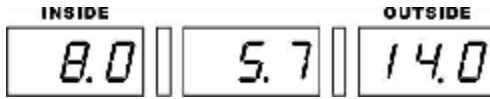

Fig 10

Function Selection

After switching on the wheel balancer, the function status is default status (i.e. the common dynamic balance status), because this function status is selected in common circumstances, more specifically, this function status can be selected in case of the pothook style counterweight can be used on both sides of wheel rim edge.

Only single-side balance is required to be performed for static balance. In this case the whole wheel is taken as having one side surface only.

Double-side balance is required to be performed for dynamic balance.

The lead weight is required to be mounted only on the outside of wheel when performing static balance operation; and that is required to be mounted on both inner side and outside of wheel when performing dynamic balance.

(Note: other function selection and application will be described later).

Inputting Wheel Data

It is important for operator to know how to input data correctly because the wrong data input may directly influence the test result of next step.

Known a=5.0", b=6.0", d=15.0".

KWB-412 balancer has the function of measuring the distance (a value) between the wheel and the balancer cabinet and the rim diameter (a value) automatically.

KWB-412 is taken as an example:

- I Pull out the measure scale into contact with the inside wall of the wheel rim, the display information on the control panel will go out because of the instable data (Fig 11).

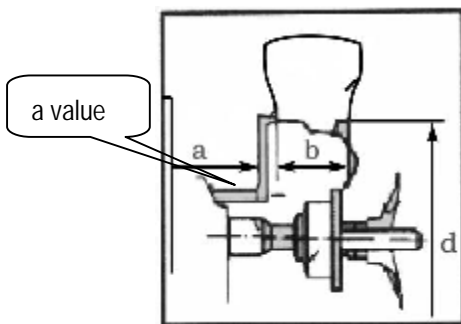

Fig 11

- I Keep the automatic measure scale close to the inner

side wall of the wheel for about 2 seconds, the LED will display the information as shown in Fig 12.

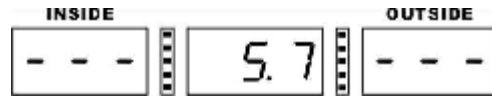

Fig 12

- I Reset the automatic measure scale, the control panel will display the data measured just now, and "a" value and "d" value are also automatically measured and displayed as shown in Fig 13.

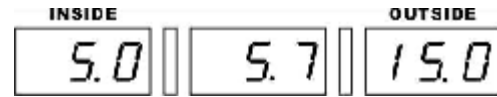

Fig 13

- I Measure the rim width with width scale according to Fig 14.

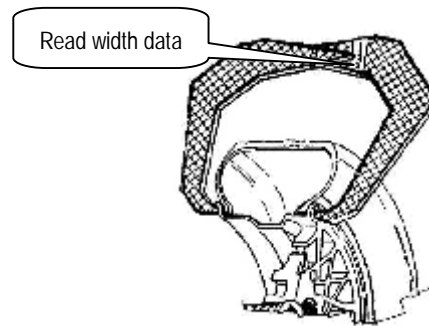
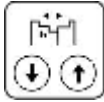

Fig 14

- I Input the data read via Up--Down key 
- I The control panel will display the information as shown in Fig 15.

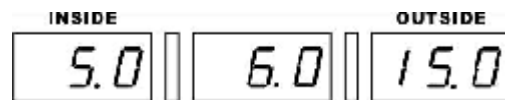

Fig 15

Imbalance value measurement

 **Attention:**

- Ø Make sure to put down the wheel protection before pressing [START] for safety operation.
- Ø Do not raise the wheel protection when the wheel is rotating. If abnormal situation occurs, press [STOP] first, then turn off the power. Don't raise wheel cover until the wheel stops.
- Ø Do not touch the machine during a wheel spin. Otherwise, the balance effect will be influenced.

The procedures for imbalance value measurement are as follows:

- I Put down the wheel protection to start the balancer (there are many kinds of start modes, please refer to the paragraph of "Composite keys for function

conversion" for other operating methods), and all LEDs will go out at this moment.

- After about 7 seconds, the control panel displays the imbalance value of the wheel, as shown in Fig 16.



Fig 16

- Meaning of the information displayed:
 - ☆ "35" indicates that the imbalance value of the wheel inner side is 35g;
 - ☆ "OPT" indicates that the imbalance value of this wheel is larger, and should be optimized. Please refer to the paragraph of "OPT Coincidence Balance Operation" for detailed operating procedures;
 - ☆ "60" indicates that the imbalance value of the wheel outside is 60g;
 - ☆ If all indicators at one side are lit, it indicates that the highest point at this side of the wheel is the imbalance position.



- Press **FINE** key, the control panel will display the actual accurate imbalance value as shown in Fig 17.

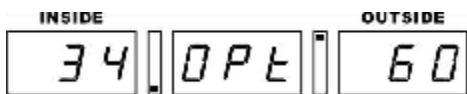

Fig 17

- Rotate the wheel, if all indicators at the outside of the wheel are lit (see Fig 18), it indicates that the highest point at the outside is the imbalance position (see Fig 19). The method to determine the imbalance position for inner side of the wheel is the same as that for outside.



Fig 18

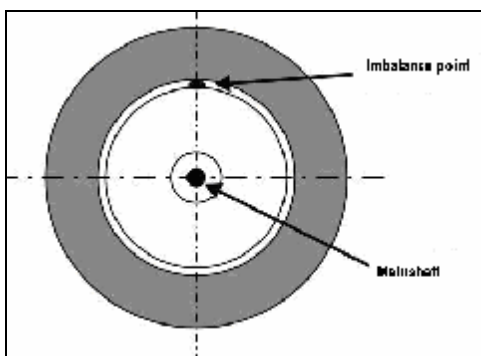

Fig 19

Compensation for wheel imbalance value

- According to the previous paragraph, attach the relative counterweight on the imbalance point of the rim. Attach the balance weight on the imbalance point as possible as you can, otherwise the compensation error will be produced.
- Perform the imbalance measurement operation again;
- The display information of the re-measurement operation is as shown in Fig 20.

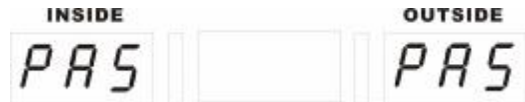

Fig 20

- The meaning of the information displayed: "PAS" indicates that the compensation for this side is up to standard (imbalance value < 5g);



- Press **FINE** key, the control panel will display the actual accurate imbalance value as shown in Fig 21. The balance operation is successful.



Fig 21

⚠ Attention:

Generally speaking, it is up to standard if the imbalance value of the wheel is less than 5g, for the balance weight uses quinary system, i.e. 5g, 10g and 15g, etc.

Static—dynamic balance mode conversion

The method for attaching the balance weight during static balance measurement is different from that during dynamic

balance measurement. Press **F** key to select static

balance mode, and repress **F** key to return to the dynamic balance mode.

- Lead-attaching method during static balance measurement: If you want to measure the wheel of motorcycle or the wheel of which both sides can not be

attached with balance lead, please press **START** key. After the tested data of imbalance value is displayed,

please press **F** key to select the lead-attaching method for static balance, and then rotate the wheel slowly. When the control panel displays the information as shown in Fig 22, all indicators at the inner side are lit. Attach the balance lead at the inner side of the wheel spoke at this moment (Fig 23).

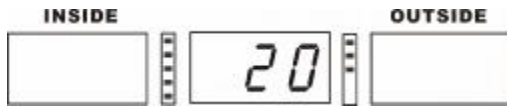

Fig 22

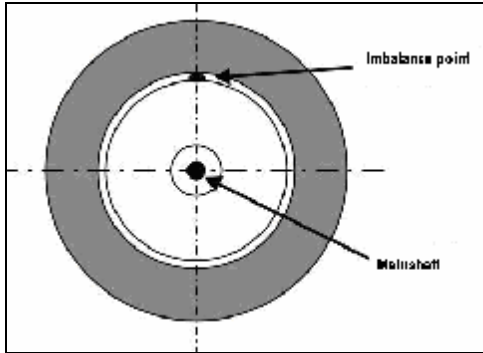

Fig 23

Operating Procedures for Special Balance Mode

ALU Wheel Drum Balance

Keep pressing **ALU** key to switch ALU operating mode. Wheel drum balance (i.e. alloy steel rim balance) includes 3 kinds of mode: ALU—1, ALU—2 and ALU—S. The lead-attaching surface of ALU—S can be set artificially according to the requirement, and can be balanced with implicated counterweight via assistant implicated program. Under ALU—1 and ALU—2 mode, the different platform can be selected to perform the lead-attaching operation according to the specific shape of the wheel drum section (see Fig 24 and Fig 25). In this way, the accurate balance position and the more accurate balance result can be obtained. Press **ALU** key one time, the ALU—1 mode is entered; press **ALU** key two times in succession, the ALU—2 mode is entered; press **ALU** key three times in succession, the ALU—S mode is entered.

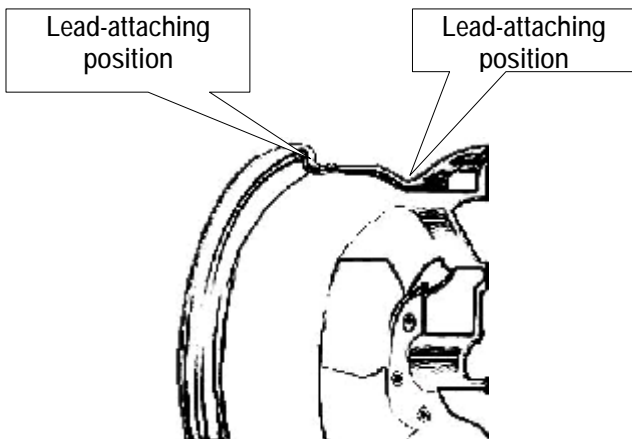

Fig 24

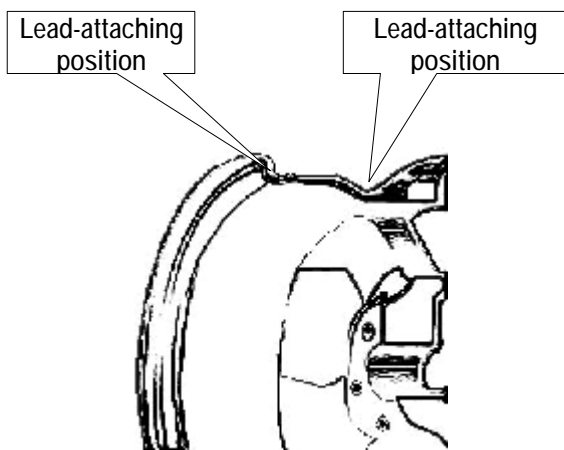

Fig 25

⚠ Attention:

KWB-402 balancer has no automatic measure scale, so it cannot use the accurate lead-attaching mode.

ALU—1 Balance Mode

After selecting ALU—1 mode, the indicators are as shown in Fig 26.

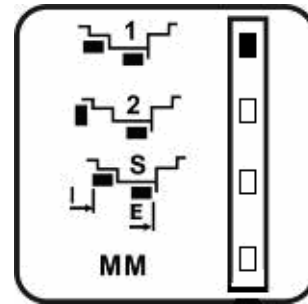

Fig 26

Press **START** key to recalculate the imbalance value of inner side and outside, the control panel will display the information as shown in Fig 27.



Fig 27

The specific operating procedures are as follows:

Rotate the wheel, let all indicators at inner side (or outside) lit. Let the lead weight side with sticking protection paper upwards, and then lift the protection paper as shown in Fig 28.

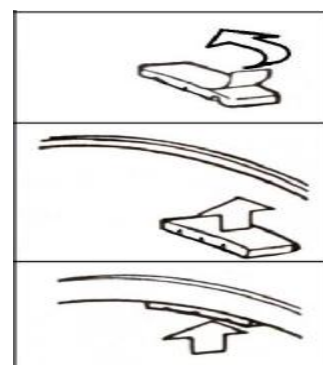

Fig 28

Move the lead weight slowly to the lead-attaching position, and attach it when arriving at the lead-attaching position. Finishing the lead-attaching operation for inner side and outside of the wheel is finishing ALU—1 operation. Perform the rotating test one more time to identify the balance effect.

Note: Keep the rim surface clean to ensure the lead weight stuck on it firmly. Perform lead-attaching

operation, if necessary, after cleaning the rim surface with appropriate amount of organic solvent or detergent.

ALU—2 Balance Mode

After selecting ALU—2 mode, the indicators are as shown in Fig 29.

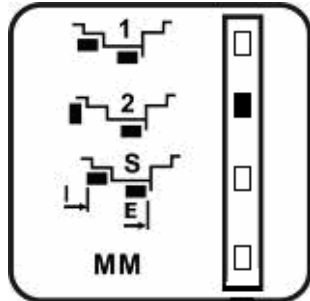

Fig 29

Press **START** key to recalculate the imbalance value of inner side and outside, the control panel will display the information as shown in Fig 30.



Fig 30

The specific operating procedures are as follows:

Rotate the wheel, let all indicators at inner side lit. The highest point of the rim inner side edge is the inner side balance point when all indicators are lit. Please attach the lead weight at the inner side of the rim according to the displayed value.

Continue to rotate the wheel, let all indicators at the outside of the wheel lit. The outside balance point is in the line parallel to the axis of the highest point close to the outside of the rim inside wall. Let the lead weight side with sticking protection paper upwards, and then lift the protection paper as shown in Fig 28.

Move the lead weight slowly to the lead-attaching position, and attach it when arriving at the lead-attaching position.

Finishing the lead-attaching operation for inner side and outside of the wheel is finishing ALU—2 operation. Perform the rotating test one more time to identify the balance effect.

Attention:

The measure scale cannot be used under ALU—1 and ALU—2 mode.

ALU—S Balance Mode

ALU—S balance mode is suitable to very special wheel rim. ALU—2 mode cannot ensure the balance of this kind of special rim.

Attention:

Please input the number of wheel spoke before

measurement.

Step 1: Input the number of the wheel spokes
After inputting the data of the wheel, and before selecting

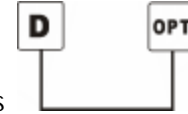

ALU mode, please press key first. The control panel will display the information as shown in Fig 31.



Fig 31



Press key again to confirm. The control panel will display the information as shown in Fig 32.



Fig 32

Attention:

If it is necessary to resolute the imbalance value to wheel spokes, the number of the wheel spokes must be input; if not, please skip Step 1 directly.

Step 2: Size-inputting method in ALU—S balance mode
al and aE indicate the lead-attaching position at the inner side of the wheel rim; dl and dE indicate the lead-attaching position at the outside of the wheel rim. Rotate the wheel, let any one of the wheel spokes on 12 o'clock position as shown in Fig 33.

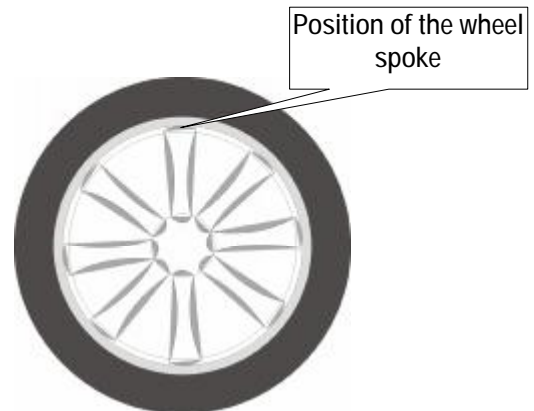

Fig 33



Press key to perform the dynamic balance operation one time, and then select ALU—S balance mode. The control panel will display the information as shown in Fig 34.

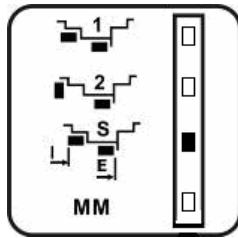

Fig 34

Input the data for lead-attaching position according to the data displayed in Fig 35 and Fig 36.

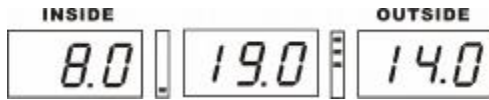
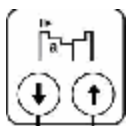

Fig 35

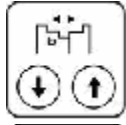

Fig 36

Let $dE = 0.8 dI$ (default value). If dI changed, dE will return to the default value. The length of the counterweight is automatically considered as 14mm when the system calculates the distance between the balancer and the center of gravity of the counterweight.



a): Press key to change the value of aI .



b): Press key to change the value of aE .



c): Press key to change the value of dI .

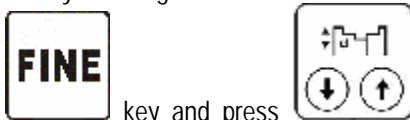

d): Keep pressing key and press key to change the value of D_e (Fig 36).

Step 3: Calculating imbalance value

After inputting the data of lead-attaching position, please rotate the wheel. If it is necessary to resolve the imbalance value, please let any one of the wheel spokes on 12 o'clock

position as shown in Fig 33, then press **START** key to perform measurement, so as to get a new imbalance value (Fig 37).



Fig 37

- I If it is necessary to resolve the imbalance value to the wheel spokes, the system will enter Step 4 directly after resolution.
- I If it is not necessary to resolve the imbalance value to

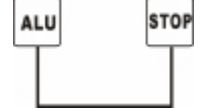

the wheel spokes, please press key (press [STOP] first, and then [ALU]) directly to perform the accurate lead-attaching operation. The control panel will display the information as shown in Fig 38.



Fig 38

The operating procedures are the same as that of Step 4.

Step 4: Resolution for imbalance value



Press key, the control panel will display the information as shown in Fig 39.



Fig 39

The resolution of the imbalance value is into 20g and 10g.



Press key to enter the accurate lead-attaching mode as shown in Fig 40.



Fig 40

Lead-attaching operation

The left screen displays the imbalance value at the inner side of the wheel rim. Rotate the wheel slowly, pull out the width scale when all indicators at inner side of the wheel are lit (Fig 41).

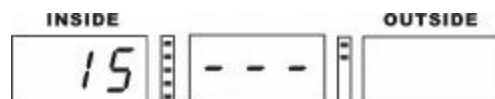

Fig 41

Keep the width scale close to the inner side wall of the wheel rim, the control panel will display the information as shown in Fig 42.



Fig 42

Attach the lead weight on the position indicated by the measure scale as shown in Fig 43.

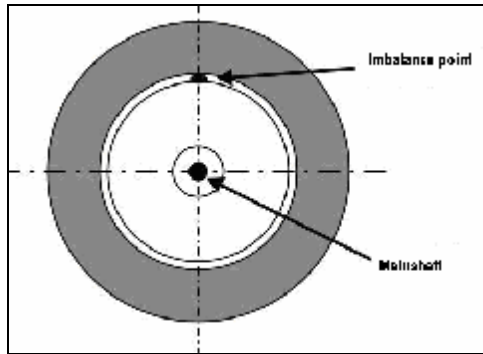

Fig 43

Rotate the wheel slowly until the right screen displays a imbalance value as shown in Fig 44.



Fig 44

Pull out the measure scale, and keep the measure scale close to the inner side wall of the wheel rim, the control panel will display the information as shown in Fig 45.

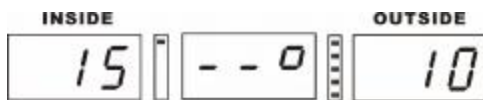

Fig 45

Attach the lead weight on the position indicated by the measure scale as shown in Fig 43.

Rotate the wheel slowly again until the right screen displays the second imbalance value as shown in Fig 46.

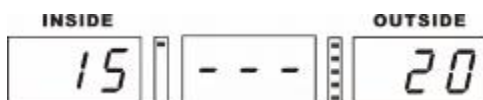

Fig 46

Pull out the measure scale, and keep the measure scale close to the inner side wall of the wheel rim, the control panel will display the information as shown in Fig 47.

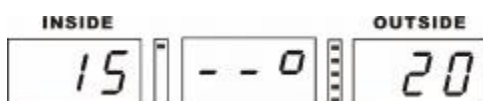

Fig 47

Attach the lead weight on the position indicated by the measure scale as shown in Fig 43.

Wheel balance operation is finished.



Press key to cancel this function.



Attention:



Press key to check the balance accuracy. The balance accuracy is 1g after finishing the balance operation.

OPT Coincidence Balance Operation

This program is used for confirming the best coincidence position between the rim and tyre, complementing the imbalance of the rim with the imbalance of the tyre, so as to reduce the weight of the balance lead added, and reduce the noise caused by bad coincidence between the rim and tyre during driving. Generally speaking, user needn't perform this operation; only in special case—when the wheel satisfies the conditions of coincidence balance, can the experienced personnel perform this operation.

Before performing the coincidence balance operation, please install the wheel on the balancer to perform the dynamic balance operation. It is only necessary to measure the imbalance value, not necessary to stick the lead weight. After operation, the control panel will display the information as shown in Fig 48.



Fig 48

The balancer makes the judgement above-mentioned according to the imbalance conditions of the wheel (the single side imbalance value of dynamic balance is more than 30g).

OPT 1



Put the wheel on the balancer, and then press  key to perform OP.1 measurement. After the wheel stops rotating, rotate the wheel slowly until all indicators are lit. Mark the highest place of the wheel outside (the side with the imbalance value of more than 30g) with chalk. The control panel will display the information as shown in Fig 49.



Fig 49

Meanwhile mark the highest place of the rim outside with chalk, and then press  key to enter OP.2 measurement phase.

OPT 2

The screen will, at that moment, display the information as shown in Fig 50.



Fig 50

Remove the wheel from the balancer, rotate the outer tyre relative to the rim, let chalk mark on the outer tyre rotated by 180 degrees. After this, please install the wheel on the balancer again to enter OP.3 phase.

OPT 3

After entering OP.3 phase, please press  key again to perform rotating operation once more; along with the finish of third rotating operation, the screen will display the optimized result as shown in Fig 51.

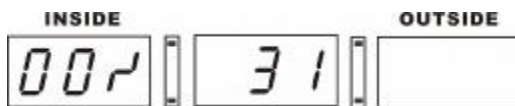



Fig 51

OPT procedures are finished.

Press  key to return to OP.1 phase again, the control panel will display the information as shown in Fig 49.

**Attention:**

- I Please perform OPT operation according to the procedures above-mentioned strictly, otherwise the mistakes will occur.
- I If the imbalance value cannot be up to the requirement, please repeat the procedures from OP.1 to OP.3.

Equipment Calibration

Self-calibration Program of the Balancer

 Attention:

The self-calibration program should be run after the equipment's first installation or if the measurement accuracy of the equipment is suspect, to ensure the measurement accuracy of the balancer.

Turn on the power supply switch of the balancer, install a wheel with medium size (13" --15"), input the data of the

wheel rim and press  key at the same time. The control panel will display the information as shown in Fig 52.



Fig 52





Release   key, put down the wheel protection, and press  key to rotate the main-shaft. The control panel will display the information as shown in Fig 53 when the main-shaft stops rotating.



Fig 53

Put down the wheel protection, and attach 100g (3.5oz) counterweight on the outside of the wheel rim. Put down the

wheel protection again, and press  key to re-rotate the main-shaft. The control panel will display the information as shown in Fig 54 when the main-shaft stops rotating.

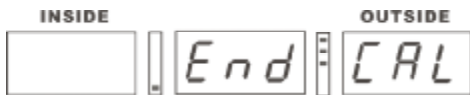



Fig 54

The self-calibration is finished, and the self-calibration data is stored in computer memory, which cannot be lost even after the balancer shutdown. The wheel balance operation can be performed after above operating procedures.

Automatic Measure scale Calibration Program

I Automatic Measure scale Distance Calibration

Press   key at the same time, the control panel will display the information as shown in Fig 55.

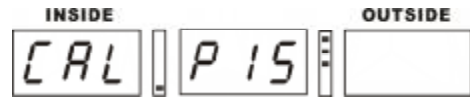

Fig 55

Move the measure scale to "0" position and hold it, as shown in Fig 56.

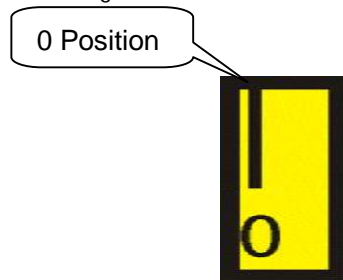



Fig 56

Press  key at the same time, the control panel will display the information as shown in Fig 57.

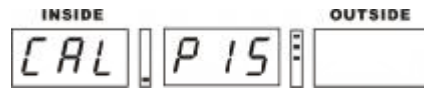

Fig 57

Move the measure scale to "15" position and hold it, as shown in Fig 58.

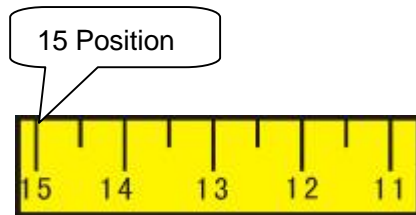

Fig 58

Press  key at the same time, the control panel will display the information as shown in Fig 59.



Fig 59

Move the measure scale to the original position, then the

calibration operation is finished.

I Automatic Measure scale Diameter Calibration
Install a wheel rim with known diameter, and then lock it.



Press   key, the control panel will display the information as shown in Fig 60.

Fig 60



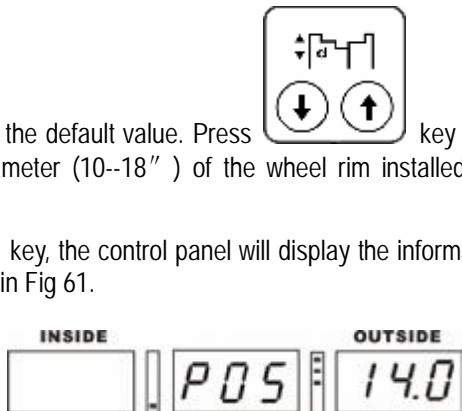

14.0 is the default value. Press  key to input the diameter (10--18") of the wheel rim installed. Press  key, the control panel will display the information as shown in Fig 61.

Fig 61



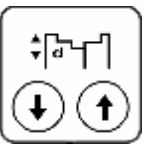

Move the measure scale to the position of diameter measurement and hold it, and then press  key at the same time, the control panel will display the information as shown in Fig 62.

Fig 62



Reset the measure scale, the calibration operation is finished.

 **Attention:**
During calibration, if input error occurs, please press [STOP] key to cancel it.

Self-Testing Program (Testing Position Sensors and Indicators)

Press  key, from left to right, the indicators flash one by one, and the control panel will display the information as shown in Fig 63.

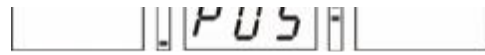



Fig 63

The position sensor can be tested at that moment. Rotate the wheel manually and slowly, indicator ALUI starts flashing, and "0" will appear on the right screen when "0" position on the main-shaft passes across the photoelectric sensor as shown in Fig 64.







Fig 64

Once the wheel turns by one circle, the [0] will appear on right screen one time. When the wheel rotates to the reverse direction, the indicator ALUS will start flashing.

Press  key, a number will be displayed on the right screen, which is the distance between the inner side wall of the wheel rim and the balancer cabinet. When moving the measure scale, this number is changed, too.

Press  key, a number will be displayed on the left screen, which is the diameter of the wheel rim. When swaying the measure scale, this number is changed, too.

Press   key at current status to return to the procedure of calibrating the diameter of the measure scale.

Press   key to return to the procedure of calibrating the distance of automatic measure scale.

 **Attention:**

The operator can press  key to exit the self-testing operation at any time.

Troubleshooting

Error Messages of Self-diagnosis

Error messages of self-diagnosis are showed below:

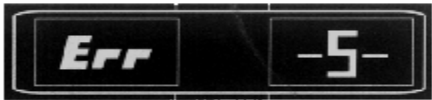
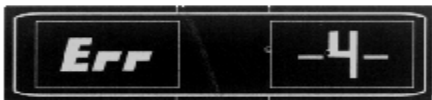
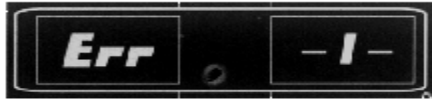

1. Failures of the single phase motor or the power supply board.
2. Low rotating speed or no wheel mounted on the machine (with tire).
3. The imbalance value is too big. Change another wheel to test.
4. Errors with power supply or position sensor.
5. The wheel protection is not put down.
7. Damages of the memory or losses of the signal.
8. Wrong calibration program or damages of the computer board or the sensor

Frequent Errors and Solution

Phenomenon	Cause	Solution
No display when turn on the machine.	<ol style="list-style-type: none"> 1. Check whether the outer power supply is normal. 2. Failures of the computer board 	<ol style="list-style-type: none"> 1. Check the outer power supply. 2. Replace the computer board.
Normal display but failures of [START] button, and a, b and d inputting keys.	<ol style="list-style-type: none"> 1. Touch switches are not sensitive. 2. Machine dies. 	<ol style="list-style-type: none"> 1. Open the cover and insert the pins of touch switches tightly. 2. Restart the machine.
Normal display but unable to stop after start, with wrong imbalance value.	<ol style="list-style-type: none"> 1. Loose connection between the computer board and the power supply board. 2. Failures of the computer board 	<ol style="list-style-type: none"> 1. Tighten the connection between the computer board and the power supply. 2. Replace the computer board.
Slow start, bad brake, and inaccurate imbalanced value	The driving belt becomes loose.	Replace the driving belt or adjust tension of the V belt.
Normal work but with inaccurate imbalance value	<ol style="list-style-type: none"> 1. Calibrated value changes. 2. The body is not stable. 3. Influences of cones or locking wing nuts. 4. The wheel is not mounted tightly. 5. Unstable power supply. 6. Big fluctuation of power voltage. 7. Failures of the raster display and its circuit. 	<ol style="list-style-type: none"> 1. Re-calibrate it according to the User's manual. 2. Solve failures according to check result. 3. If the failure still exists, replace the computer board. 4. Re-fasten locking wing nuts.

 **Attention:**

If the problems can not be fixed through above solutions, please contact the technical support personnel.

Maintenance



Attention:

Only the specialized technician can do the maintenance. Before any maintenance is performed, disconnect the power and keep the plug within the sight of the maintenance personnel.

To keep the wheel balancer in good condition and to prolong its work life, it is necessary to do regular maintenance according to the instructions of this manual. Otherwise, the normal operation and reliability of the machine will be influenced, or personal injury would be caused.

- I Keep the machine and working area clean, prevent dust from entering the moving parts.
- I Keep the balance shaft clean (clean with diesel oil or alcohol) and lubricated.
- I Regularly calibrate the machine. See *Installation and Parts Manual* for details.
- I Regularly check and adjust the tension of the belt.
- I Check all connecting parts and bolts regularly and tighten them if necessary.

Storage and Scrapping

Storage

When the equipment needs to be stored for a long extended period of time:

- I Disconnect the power.
- I Lubricate all the parts that need to be lubricated: main shaft and etc.
- I Protect the machine with plastic cover against dust.

Scrapping

When the equipment can no longer be used, disconnect the power and dispose it in accordance with the local law and regulations.

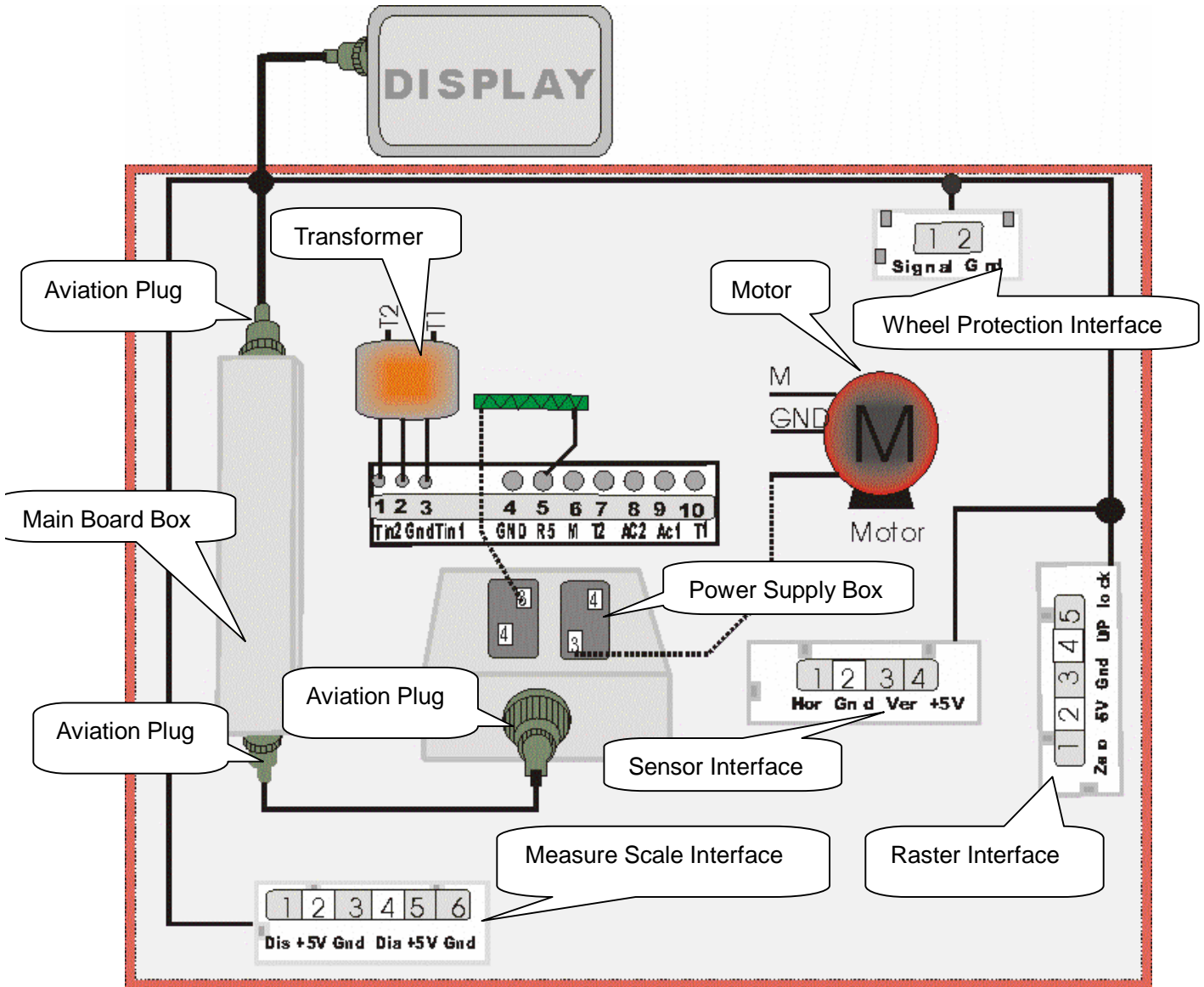

KWB-412 Circuit Diagram

Warranty

Xinyang Building, Bagua 4th Road,
Shenzhen, Guangdong Province,
P. R. China
P.C.: 518029

-THIS WARRANTY IS EXPRESSLY LIMITED TO PERSONS WHO PURCHASE LAUNCH PRODUCTS FOR PURPOSES OF RESALE OR USE IN THE ORDINARY COURSE OF THE BUYER'S BUSINESS.

LAUNCH products is warranted against defects in materials and workmanship for one year from date of delivery to the user. This warranty does not cover any part that has been abused, altered, used for a purpose other than for which it was intended, or used in a manner inconsistent with instructions regarding use. The exclusive remedy for any automotive meter found to be defective is repair or replacement, and LAUNCH shall not be liable for any consequential or incidental damages. Final determination of defects shall be made by LAUNCH in accordance with procedures established by LAUNCH. No agent, employee, or representative of LAUNCH has any authority to bind LAUNCH to any affirmation, representation, or warranty concerning LAUNCH products.

Declaration

The above warranty is able to replace any warranty in other forms.

Order Information

Replaceable and optional parts can be ordered directly from your LAUNCH authorized supplier. Your order should include the following information:

1. Quantity
2. Part code
3. Item description

Customer Service

If you have any questions on the operation of the machine, please contact us:

Tel: 86-755-82269474, or fax: 86-755-82264570

If your machine requires repair service, return it to the manufacturer with the sales invoice, the warranty sheet, the quality certificate and a note describing the problem. If the machine is determined to be in warranty, LAUNCH will repair or replace at no charge, also repay the transport fee to the customer. If the machine is determined to be out of warranty, it will be repaired for a nominal service charge plus return freight. Our address is as follows:

Attn: Overseas Department
LAUNCH TECH. CO., LTD.